

TOOL REQUIRED: #2 PHILLPS SCREWDRIVER

### INSTALLATION OUTSIDE OF CABINET: (RECOMMENDED)

STEP 1. SET ASIDE FILTER PRIOR TO ASSEMBLY.

STEP 2. ASSEMBLE FOUR PAN HEAD SCREWS PROVIDED FOR THE FILTER KIT AS SHOWN IN FIGURE 1.

STEP 3. INSTALL FILTER AS SHOWN IN DETAIL B.

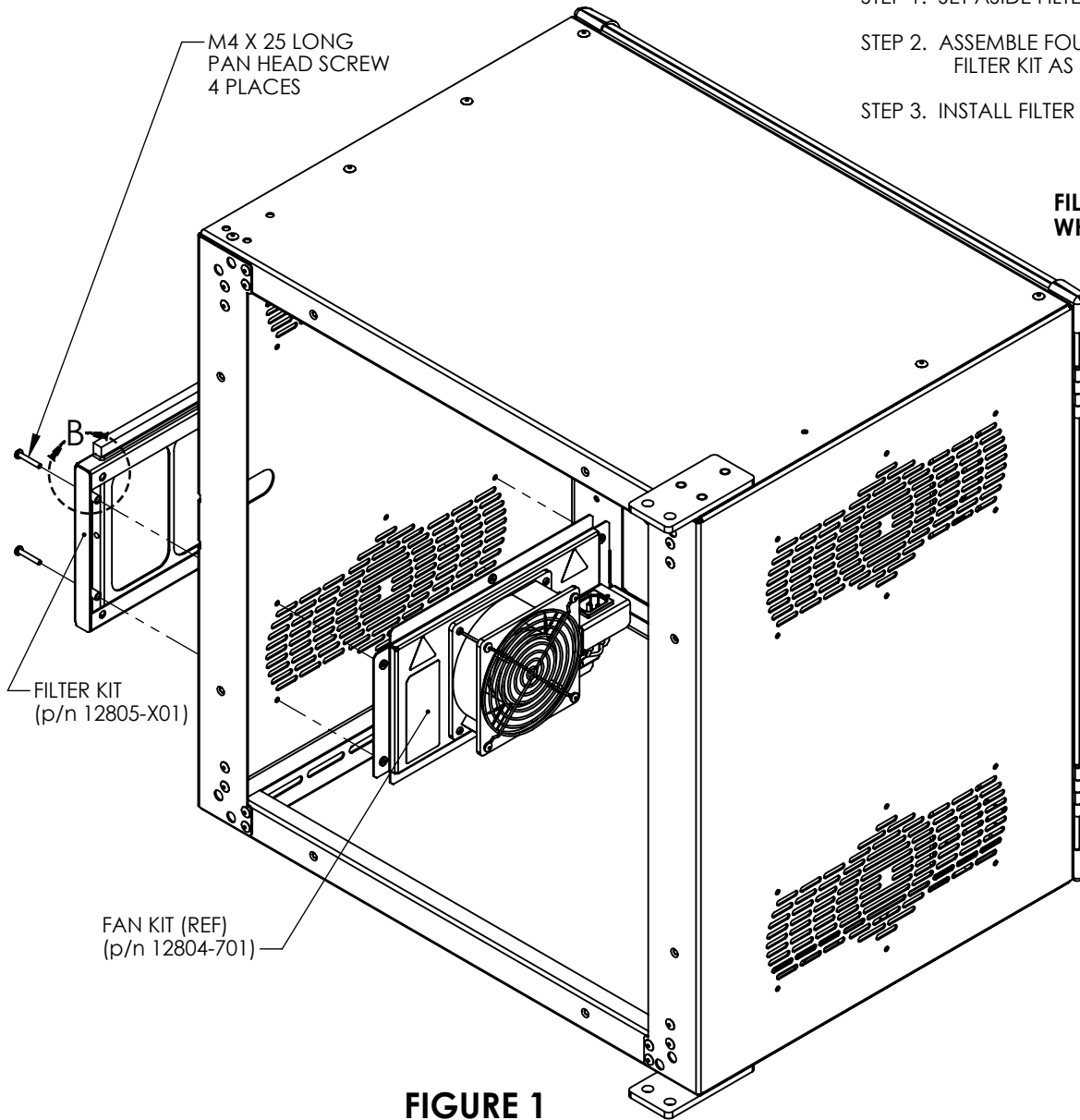

**NOTE: REAR PANEL AND RAIL NOT SHOWN FOR CLARITY**

**FILTER PROPERLY INSTALLED WHEN FURTHEST FROM THE FAN**

**\*\*IMPORTANT\*\* THIS SURFACE TOWARD FAN**

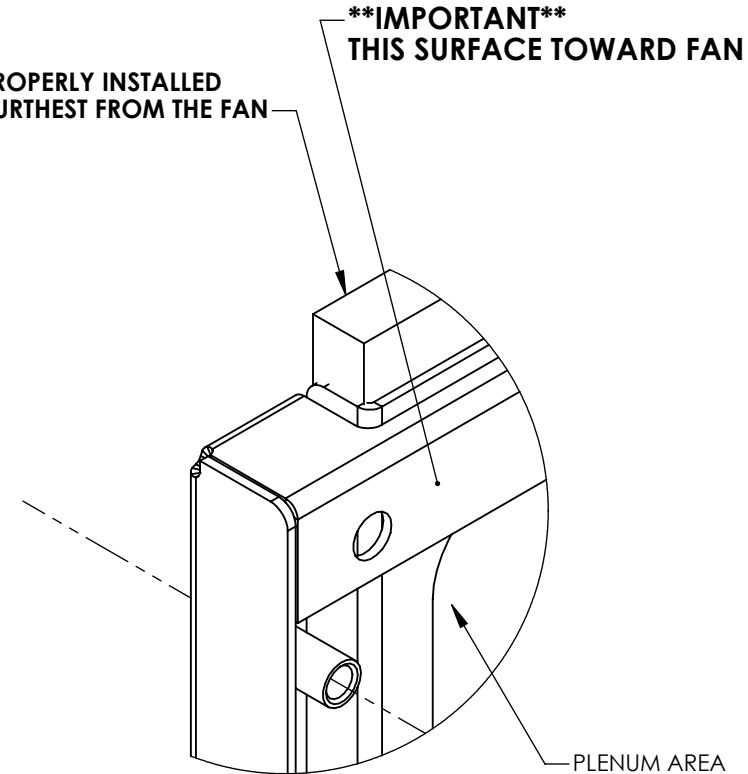

**CPI CHATSWORTH PRODUCTS, INC.**

**INSTALLATION INSTRUCTIONS, FILTER KIT, CUBE IT**

THIS DRAWING CONTAINS INFORMATION PROPRIETARY TO CHATSWORTH PRODUCTS, INC. ANY REPRODUCTION DISCLOSURE OR USE OF THIS DRAWING IS EXPRESSLY FORBIDDEN EXCEPT AS AGREED TO IN WRITING BY CHATSWORTH PRODUCTS, INC.

## \*\* INSTALLATION INSIDE OF CABINET:

STEP 1. SET ASIDE FILTER PRIOR TO ASSEMBLY

STEP 2. ASSEMBLE ONE PAN HEAD SCREW (M4x10 LONG) FROM THE FAN KIT TO AID IN ASSEMBLY OF THE FILTER AND FAN KIT AS SHOWN IN DETAIL C. THIS TECHNIQUE WILL AID IN HOLDING BOTH KITS TOGETHER WHEN MOUNTING INSIDE CABINET. ENSURE THAT THE SCREW IS WELL TIGHTENED.

STEP 3. ASSEMBLE FOUR PAN HEAD SCREWS PROVIDED FOR THE FILTER KIT AS SHOWN IN FIGURE 2.

STEP 4. INSTALL FILTER AS SHOWN IN DETAIL B OF SHEET 1.

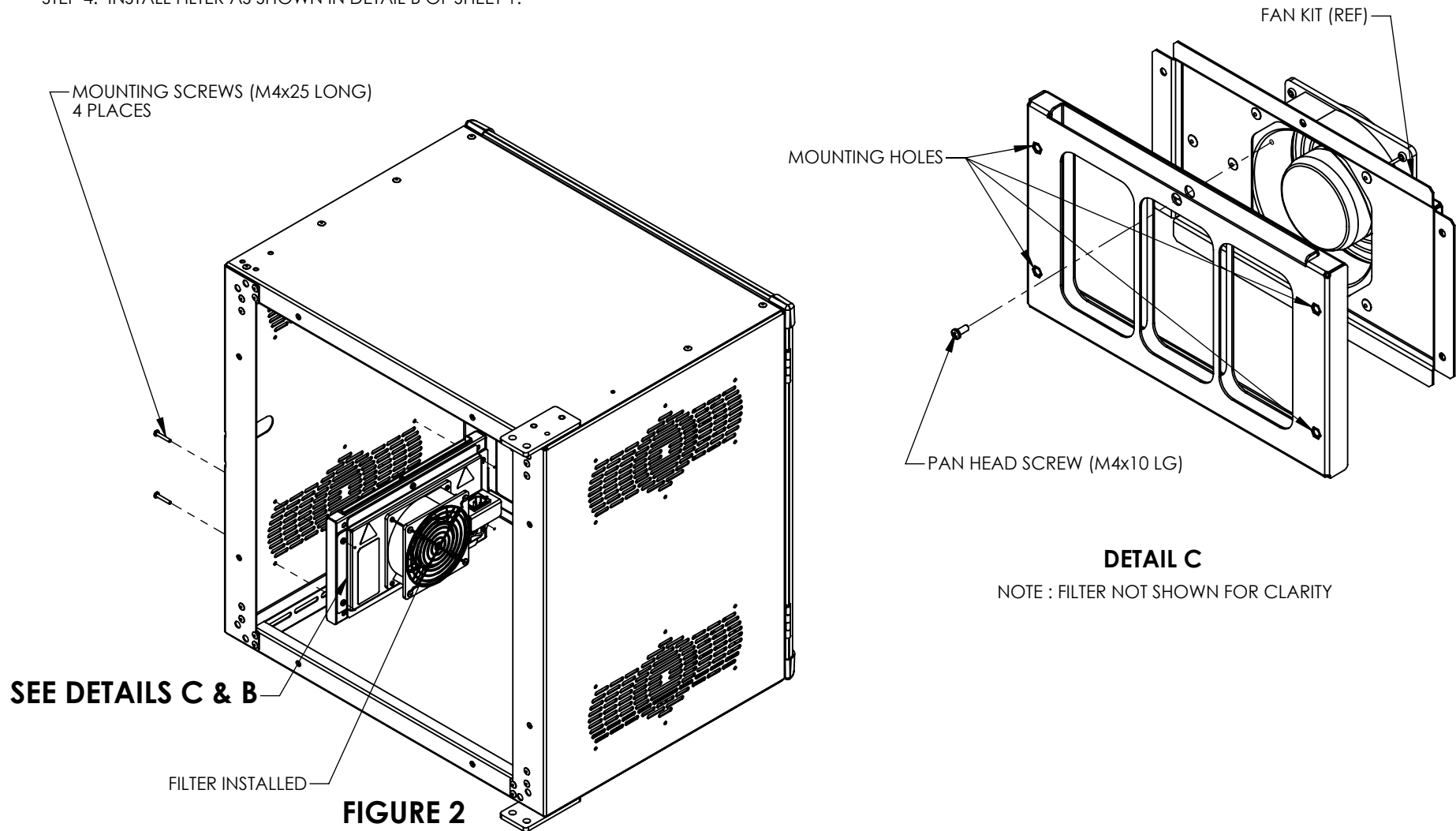

**\*\* NOTE THAT WHEN MOUNTING BOTH (FILTER AND FAN KIT) ON THE INSIDE OF THE CABINET, THE BOTTOM THREE (3) RMU'S ARE RESTRICTED TO SHALLOW EQUIPMENT THAT DOES NOT BLOCK THE FAN EXHAUST.**